



875-0051-01 Rev1

# *M5e Accessory Hardware Guide*

**Government Limited Rights Notice:** All documentation and manuals were developed at private expense and no part of it was developed using Government funds.

The U.S. Government's rights to use, modify, reproduce, release, perform, display, or disclose the technical data contained herein are restricted by paragraph (b)(3) of the Rights in Technical Data — Noncommercial Items clause (DFARS 252.227-7013(b)(3)), as amended from time-to-time. Any reproduction of technical data or portions thereof marked with this legend must also reproduce the markings. Any person, other than the U.S. Government, who has been provided access to such data must promptly notify ThingMagic, Inc.

ThingMagic, Mercury, Reads Any Tag, and the ThingMagic logo are trademarks or registered trademarks of ThingMagic, Inc.

Other product names mentioned herein may be trademarks or registered trademarks of ThingMagic, Inc. or other companies.

© Copyright 2000–2009 ThingMagic, Inc. All Rights Reserved

ThingMagic, Inc.  
One Broadway, 5th floor  
Cambridge, MA 02142  
866-833-4069

01 Revision 1  
September, 2009

# Contents

---

<b>Accessory Board Configuration</b> .....	<b>3</b>
<b>Introduction</b> .....	<b>3</b>
<b>4 Port Multiplexer Board</b> .....	<b>4</b>
External MUX Control (Block 23) .....	5
M5e Control (Block 23) .....	6
Terminal Block 23 Pins .....	8
Antenna Detection .....	9
<b>Power/Interface Board</b> .....	<b>10</b>
USB Interface .....	11
Alternate Command Interface (Block J3) .....	11
Alternate GPIO Interface (Block J7) .....	12
Alternate Power Input (Block J1) .....	12
EU Regulatory Warning .....	12
<b>Accessory Parts Kit</b> .....	<b>13</b>
<b>Connecting the Accessory Boards</b> .....	<b>15</b>
<b>Appendix A: Accessory Specifications</b> .....	<b>17</b>
<b>4 Port Multiplexer</b> .....	<b>18</b>
<b>Power Interface</b> .....	<b>19</b>
<b>Heatsink</b> .....	<b>20</b>

# Accessory Board Configuration

---

## Introduction

This document describes the ThingMagic M5e Module Accessory hardware and how to configure them for use with the M5e Embedded Module. These accessories are primarily designed for use with the M5e Module but can also be used with the M5e-Compact (except the heatsink) with minor modifications to the instructions.

These accessories allow developers to quickly create prototypes and products to meet a wide variety of applications.

- ◆ The [4 Port Multiplexer Board](#) allows one M5e module to support up to 8 ports (using two multiplexers); compatible with M5e antenna detection and search algorithms.
- ◆ The [Power/Interface Board](#) converts the M5e serial interface to high speed USB and conditions incoming DC power to support in-vehicle or AC powered applications.
- ◆ The M5e heatsink allows use of the M5e module in environments where continuous reading or high ambient temperatures are required.
- ◆ The optional hardware [Accessory Parts Kit](#) contains sufficient interconnect cables and mounting/spacing hardware to create an 8-port reader “stack”.

# 4 Port Multiplexer Board

The multiplexer board contains the following important I/O and control components:

## Multiplexer Components

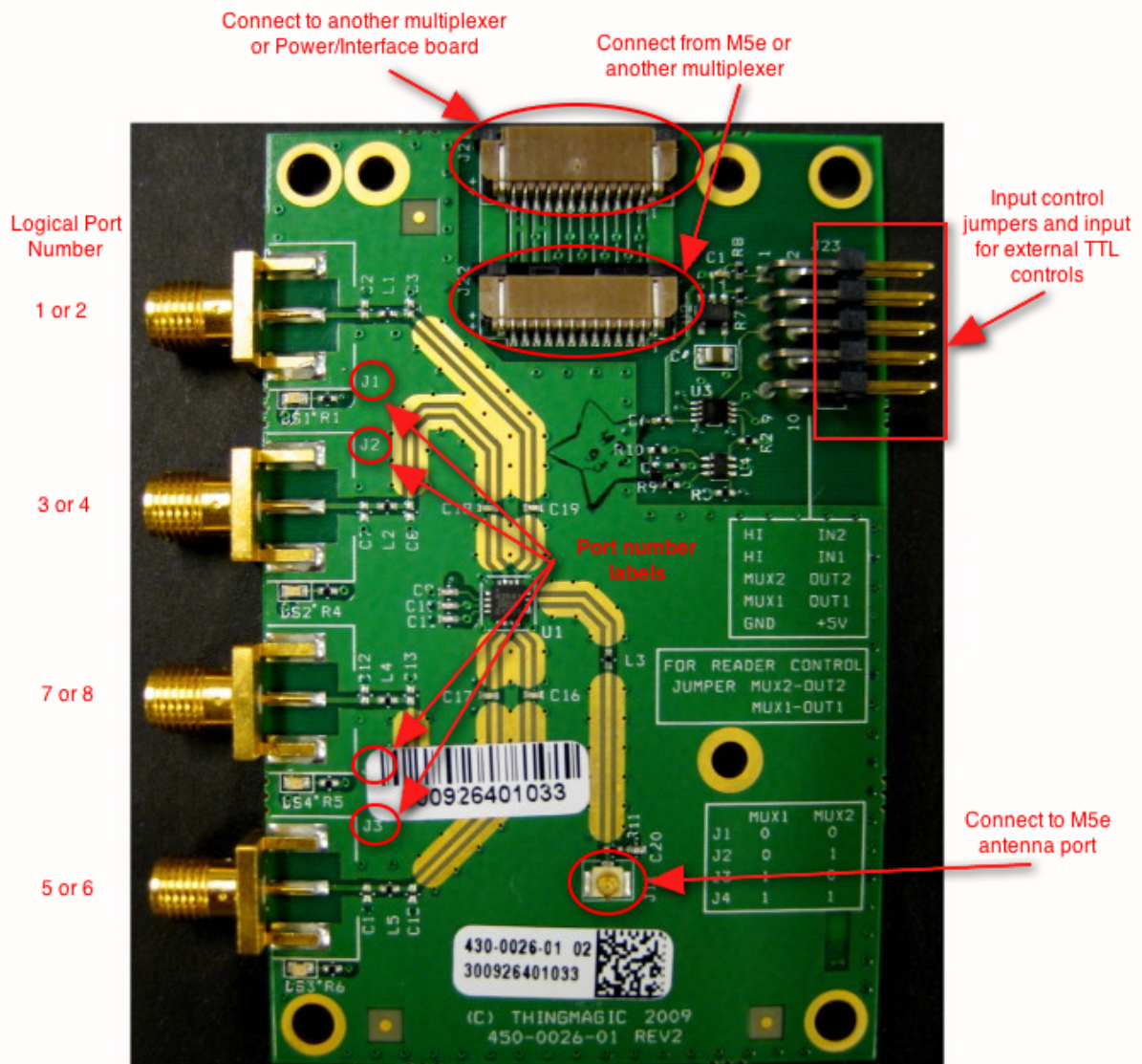

The physical antenna port in use, labeled J1 through J4 on the board, is controlled by the MUX1 and MUX2 input lines on the input terminal connector. The control map is as follows:

**Antenna Port Control Lines**

	MUX1	MUX2
<b>J1</b>	0	0
<b>J2</b>	0	1
<b>J3</b>	1	0
<b>J4</b>	1	1

Note

Interpreting the control lines as binary “numbers” gives an incorrect order relative to the physical order of the ports. A key printed on the board serves as a reminder that, from left to right when looking down at the board, the port order is J1 – J2 – J4 – J3.

These lines can be controlled directly by an external controller/motherboard providing TTL signals or by using signals from the M5e.

## External MUX Control (Block 23)

When controlling the Multiplexer using external TTL signals the terminal pins on the board serve as input signals as defined in [Antenna Port Control Lines](#) table. In this configuration the M5e software has no knowledge of which multiplexed line is in use. All antenna ports on a Multiplexer will look like Antenna 1 or 2 (depending on which M5e port is used) and the associated *Antenna ID* metadata will be the same for all four ports. It is the users responsibility to manage coordination between the MUX control line settings and the M5e RF operations and tag response data.

For this configuration no jumpers should be present on terminal block 23.

## M5e Control (Block 23)

The Multiplexer can be controlled using the M5e GPOutput lines by connecting the ribbon cable between the M5e and the Multiplexer board and adding jumpers on the terminal pins, connecting **MUX2** with **OUT2** and **MUX1** with **OUT1**.

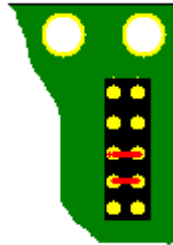

This method allows the M5e to use its built-in support for (up to 8) multiplexed antennas. This enables automatic control of GPO to MUX signals to switch ports based on the M5e logical antenna setting and association of tag read information with the corresponding antenna ID meta data.

When using the M5e built-in multiplexer support the ports are also identified by pre-defined logical port numbers - **this requires M5e firmware version 1.3.0 or later**. In a stacked configuration, multiplexers are installed upside-down relative to the M5e board. Assuming that the multiplexer closest to the M5e is connected to M5e port 1 and the one farthest is connected to M5e port 2, the logical port numbers would be as shown here:

### Logical Port Configuration

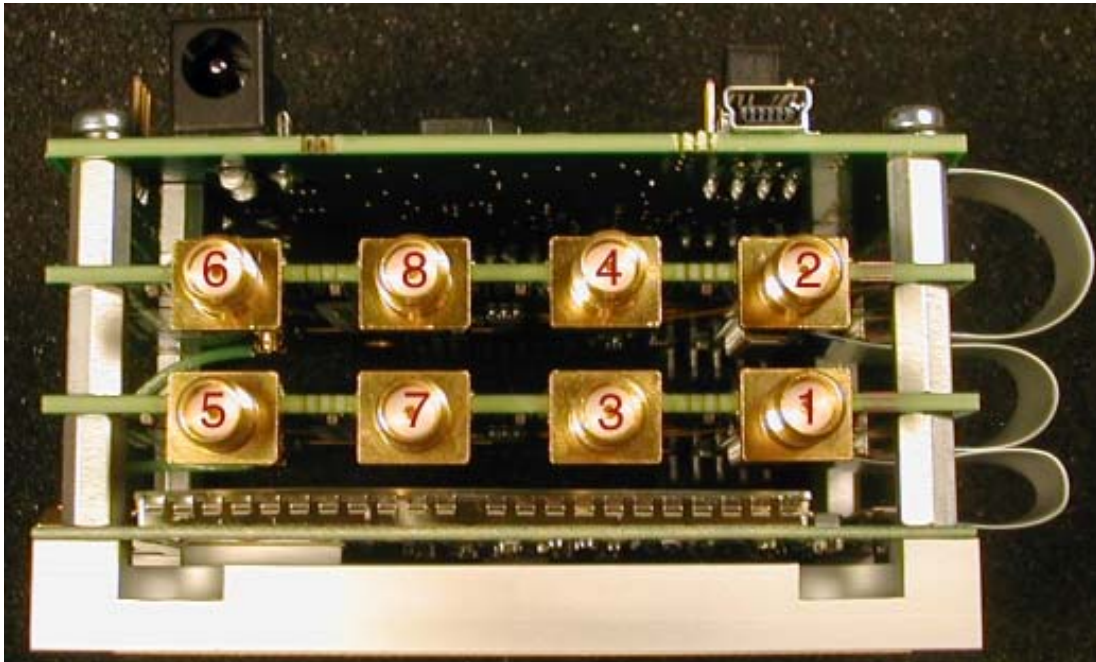

The reason for numbering the logical ports in this way was so that “logical port 1” would stay associated with physical port 1 on the module whether there was a multiplexer connected to it or not and, similarly, “logical port 2” would stay associated with physical port 2 whether there was a multiplexer connected to it or not. If the application calls for a mixture of manual control of the multiplexer (via physical port selection and GPIO Output line manipulation) and automatic control (by configuring a search list of logical antennas), the benefits of this numbering system will be more clear.

The resulting full control map with physical and logical port numbering is:

**Physical to Logical Port Map**

	MUX1	MUX2	Logical Port when connected to port 1 of M5e	Logical Port when connected to port 2 of M5e
<b>J1</b>	0	0	1	2
<b>J2</b>	0	1	3	4
<b>J3</b>	1	0	7	8
<b>J4</b>	1	1	5	6

## Terminal Block 23 Pins

The following [Block 23 Pin Function Summary](#) table contains a detailed list of the terminal block 23 pins and their function based on the overall board configuration, whether the multiplexer to M5e ribbon cable is connected and whether the jumper blocks are connecting the multiplexer to a controller motherboard. A printed key on the multiplexer board below the terminal pins also indicates which jumper pins are connected to which internal function.

**Block 23 Pin Function Summary**

<b>Terminal pin</b>	<b>What it is connected to</b>	<b>If multiplexer is connected to motherboard through the ribbon cable connector</b>	<b>If multiplexer is connected to motherboard through Molex connector to jumper block</b>
IN1	GPIO Input #1 (Input to module)	Ignore	Bring in GPIO Input signal to module through this pin. If no ribbon cable connection, it is naturally pulled low. Jumper to "HI" if the application requires this input to be driven high at all times.
IN2	GPIO Input #2 (Input to module)	Ignore	Bring in GPIO Input signal to module through this pin. If no ribbon cable connection, it is naturally pulled low. Jumper to "HI" if the application requires this input to be driven high at all times.
MUX1	Mux switch control	Jumper to OUT1 (GPIO Output #1) if multiplexer is to be controlled by module.	Use this pin to bring in external control from motherboard if multiplexer is not controlled through ribbon cable.

MUX1	Mux switch control	Jumper to OUT1 (GPIO Output #1) if multiplexer is to be controlled by module.	Use this pin to bring in external control from motherboard if multiplexer is not controlled through ribbon cable.
+5	+5V source to multiplexer	Ignore	Use this pin to bring in +5V from motherboard if multiplexer is not connected to power source through ribbon cable.
Gnd	Ground to multiplexer	Ignore	Use this pin to bring ground to multiplexer from motherboard if multiplexer is not connected to power source through ribbon cable.

## Antenna Detection

When using the multiplexer in the [M5e Control \(Block 23\)](#) configuration the M5e functionality for manually (Get Antenna Configuration - 61h command) and automatically (Set Reader Configuration - 9Bh, option 0x04 - *Check Antenna Connection*) detecting connected antennas can be used.

This functionality requires the M5e module to be running firmware v1.3.0 or later.

### Note

Reliable antenna detection requires that an attached antenna pass at least a small amount of DC current. Many antennas do not pass DC current. Due to such antennas an indication that a port is connected/terminated is always accurate, but an indication that a port is not connected/terminated may not be accurate.

# Power/Interface Board

The Power/Interface board has one set of jumper blocks and three sets of terminal blocks as shown in the [Power/Interface Components](#) image below.

**Power/Interface Components**

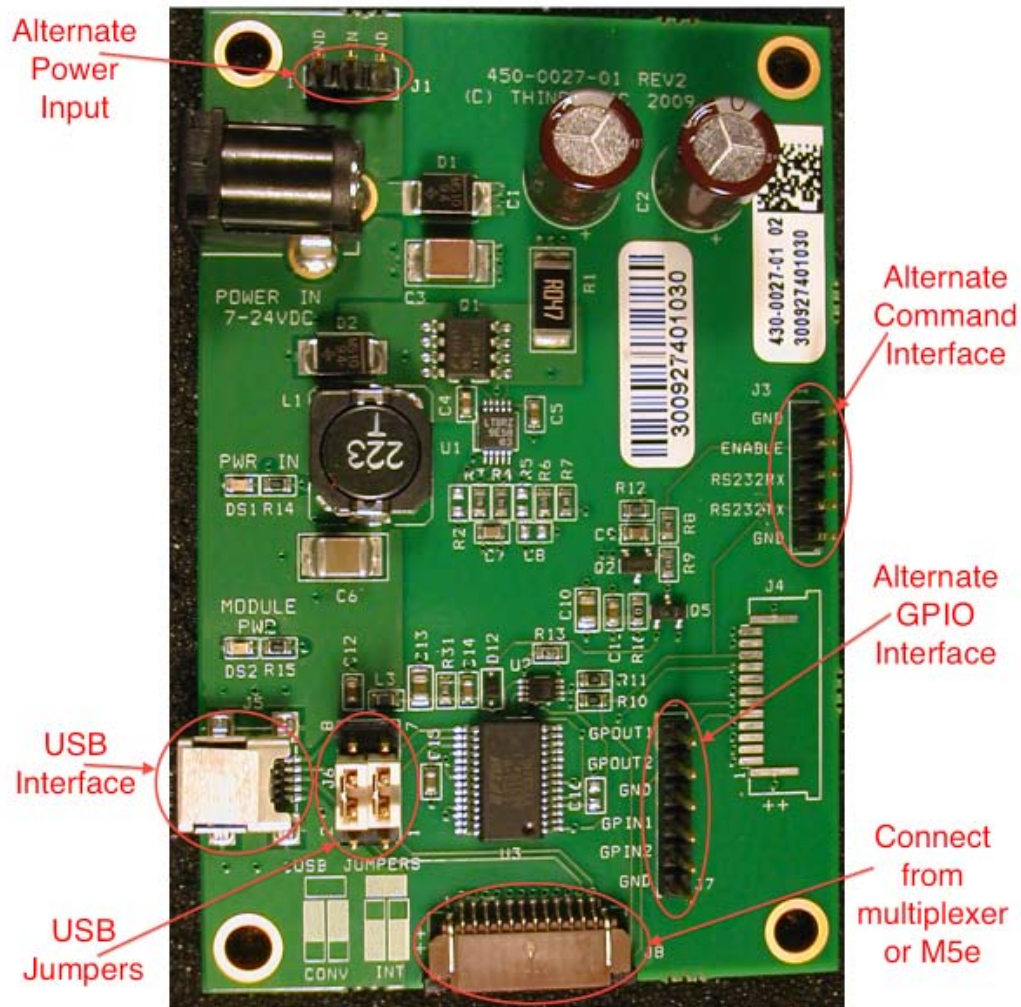

## USB Interface

The power/interface board uses the FTDI FT232R IC for its USB interface. Drivers and installation guides for installing the necessary device drivers along with source code to build the drivers for many other operating systems can be found at:

<http://www.ftdichip.com/Drivers/VCP.htm>

To use the USB connector, configure the USB jumpers as shown in the diagram next to the jumper block (the CONV configuration, the INT setting is not supported) and in the [Power/Interface Components](#) image above.

## Alternate Command Interface (Block J3)

Terminal block J3 is used for two purposes:

- ◆ Provide alternative transmit and receive signal interface (compatible with Molex-style connector) if TTL rather than USB is used for input and enable signals.

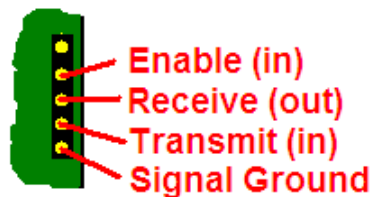

- ◆ Provide an alternate means of enabling the module if USB is not used (and therefore the 5V USB input signal is not available). Jump GND pin to Enable pin to turn on module permanently:



## Alternate GPIO Interface (Block J7)

Terminal block J7 provides a TTL interface for reading and controlling the GPIO lines of the module (via Molex-style connectors).

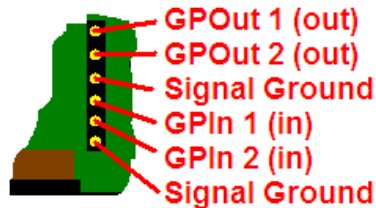

## Alternate Power Input (Block J1)

Terminal block J1 is used to bring DC power (7 to 24 V) into the module through a Molex-style connector as an alternative to using the round 2.1mm jack.

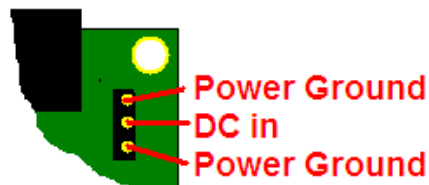

## EU Regulatory Warning



**W A R N I N G !**



**The Power / Interface board does not pass EU regulations for unintentional radiation without additional shielding. It does pass FCC regulations.**

---

## Accessory Parts Kit

The following parts are included in the optional parts kit which provides all the necessary parts to build up an 8-port multiplexer using two [4 Port Multiplexer Board](#), a [Power/Interface Board](#), a heat sink and an M5e. The label before each part refers to its location in the full assembly as show in the [Accessory Parts Kit Diagram](#).

### **A, B, C:** M/F Standoffs, M3, 10 mm

**Notes:** Stand-offs for first multiplexer, second multiplexer and power/interface board.

**Part Number:** Digi-Key 24337K-ND

### **D:** MMCX to U.FL (IPX) cable, RTANG Plug

**Notes:** RF Cable for multiplexer

**Part Number:** Lighthouse Technologies CB1.32-IPX-MCLMGT-1.5"-NH

### **E:** M3 pan-head screws, 6 mm (DIN 7985)

**Notes:** Screw for top board

**Part Number:** Digi-Key H742

**Part Number:** McMaster-Carr 92005A116

### **F:** M3 Flat Lockwashers (DIN 7980)

**Notes:** Washer for top board

**Part Number:** McMaster-Carr 91111A118; 100 for \$1.43

### **G:** 2" Ribbon Cable, 12 pos, 1mm pitch

**Notes:** Only short cables needed if power/interface board mounted upside-down as are multiplexers.

**Part Number:** Digi-Key WM10003-ND (Molex 21039-0269)

**Accessory Parts Kit Diagram**

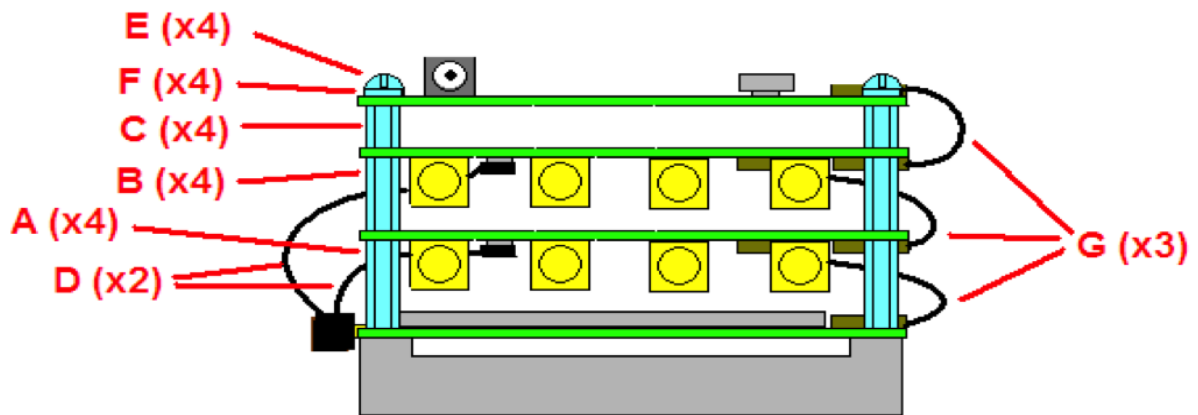

## Connecting the Accessory Boards

The multiplexer is designed so that it can be mounted above or to the side of the M5e module. Either way, it is best to connect the modules to each other side by side, and then, if desired, rotate one module above the other. Refer to the section that explains how the boards are installed for detailed information.

The multiplexer is connected to the module as shown below. (The contacts on the ribbon cable are facing down). This same connection method can be used for the power/ interface board except in the side-by-side configuration it will face component side down

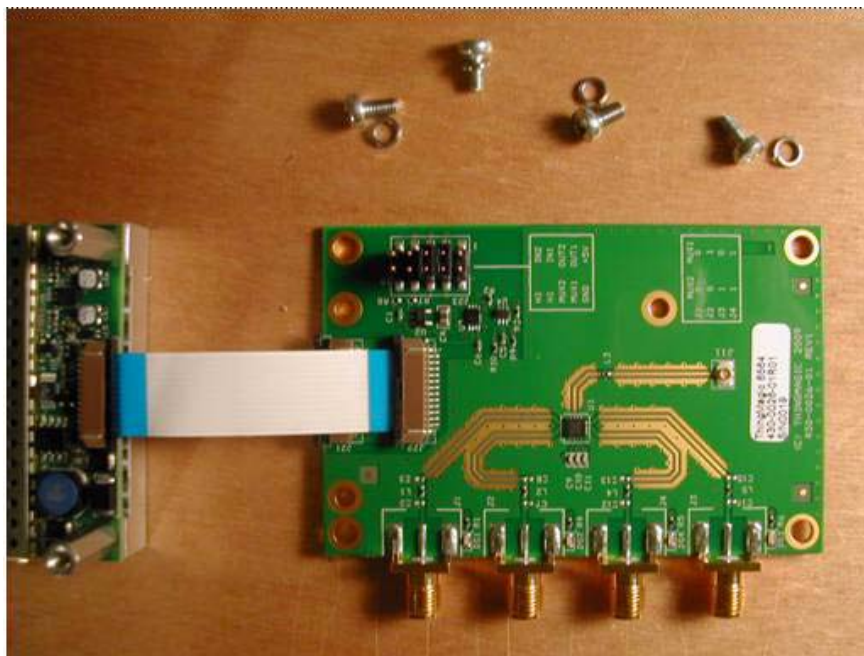

As noted previously, if the multiplexer is stacked on top of the module, it will be upside down with respect to the module.

A full stack, of an M5e, 2 multiplexers, a power board and heat sink, will stack as shown below in the [Logical Port Configuration](#) image and the [Accessory Parts Kit Diagram](#).





# Appendix A: Accessory Specifications

---

---

## 4 Port Multiplexer

### Compatibility

M5e, M5e-EU or M5e-Compact Modules

### RF Ports

One 50 Ohm U.FL Common port; 4 SMA Switched Ports

### Control Ports

Two module TTL GPIO lines on two “Pass Through” 12-Pin ZIF Ribbon cable connectors or TTL on terminal block

### Insertion Loss

1 dB max

### Frequency Range

840 – 960 MHz with DC pass-through for antenna detection

### Power

3 to 5.5 V, 1 mA max

### Operating Temp.

-40° to +85°C

### Dimensions

82 mm L x 64 mm W (including connector overhang) x 8.5 mm H

# Power Interface

## Interfaces

Power Input: 2.1mm DC input jack; Interface Input: USB mini-B jack or TTL on terminal block; Interface and Power Output: 12-pin ZIF ribbon cable connector

## Output Power

5 V +/- 0.25 V at 2 A max

## Input Power

8 to 24 VDC (12.5 W max, max current depends on voltage) (USB 5V is used only to detect port is active, not to power module)

## Operating Temperature

-40° to +65°C

## Dimensions

82 mm L x 56 mm W (including connector overhang) x 15 mm H

## USB Interface

Up to 921.6 kbps (limit of M5e module)

---

# Heatsink

## Compatibility

Supports M5e and M5e-EU Modules

## Dimensions

82 mm L x 54 mm W x 10 mm H

## Mounting

M5e module is mounted to the heatsink using off-the-shelf M3 hardware (not included). Heatsink can be mounted to chassis via M3 screws or M3 threaded mounting posts & nut. Thermal pads are included.