

Vega Reader Setup Guide



Government Limited Rights Notice: All documentation and manuals were developed at private expense and no part of it was developed using Government funds.

The U.S. Government's rights to use, modify, reproduce, release, perform, display, or disclose the technical data contained herein are restricted by paragraph (b)(3) of the Rights in Technical Data – Noncommercial Items clause (DFARS 252.227-7013(b)(3)), as amended from time-to-time. Any reproduction of technical data or portions thereof marked with this legend must also reproduce the markings. Any person, other than the U.S. Government, who has been provided access to such data must promptly notify Trimble.

ThingMagic, Mercury, Reads Any Tag, and the ThingMagic logo are trademarks or registered trademarks of Trimble.

Other product names mentioned herein may be trademarks or registered trademarks of Trimble or other companies.

©2011 ThingMagic – a division of Trimble Navigation Limited. ThingMagic and The Engine in RFID are registered trademarks of Trimble Navigation Limited. Other marks may be protected by their respective owners. All Rights Reserved.

ThingMagic, A Division of Trimble
One Cambridge Center, 11th floor
Cambridge, MA 02142
866-833-4069

03 Revision A
August, 2011

Contents

ThingMagic Vega	
Set Up Guide	5
Introduction	6
In-vehicle Reader Notes	6
Included Components	7
Additional required equipment:	7
Setting up Vega	8
Connecting the Antenna(s)	8
Using Three Antennas	8
Powering up Vega	9
Reading Tags	10
Start the Universal Reader Assistant	10
Using GPIO and ReaderEnable	11
GPIO	11
GPIO Logic Voltage Levels	11
ReaderEnable	12
Mechanical	13
Mounting the Reader	13
Rack Mount Considerations	14
Elevated Operating Ambient	14
Reduced Air Flow	14
Mechanical Loading	14
Circuit Overloading	14
Reliable Earthing	14
Vega Specifications	15
Power	15
AC/DC Power Required	15
Environment	15
Operating Temp	15
Storage Temp	15

Automotive Environmental Standards	16
Electrostatic Discharge.....	16
Architecture.....	16
RFID ASIC	16
User-accessible Flash Memory	16
Tag Buffer	16
Performance	17
Tag Read Rate.....	17
Tag Read Distance	17
Tag / Transponder Protocols.....	17
RFID Protocol Support.....	17
Regional Support	17
RF Interface.....	17
Antenna Connector.....	17
RF Power Output	17
Data/Control Interface	18
Data/Control	18
GPIO Sensors and Controls	18
Protocol	18
Physical	18
Dimensions	18
Compliance Information	19
FCC COMPLIANCE.....	19



ThingMagic Vega Set Up Guide

Introduction

The Vega Reader kit is a self-contained reader that can be deployed as a UHF RFID reader with a standard serial interface. The Vega is built on the ThingMagic M5e module. For more information on the M5e please see the *M5e-Family Developer's Guide*.

This document provides an overview of the hardware and basic command and control of the Vega. The ThingMagic Vega RFID Reader is compatible with ThingMagic's application development tools, including the cross-product MercuryAPI, permitting rapid creation of solutions to support a wide range of applications.

The MercuryAPI supports Java, .NET and C programming environments. The MercuryAPI Software Development Kit (SDK) contains sample applications and source code to help developers get started demoing and developing functionality. For more information on the MercuryAPI see the MercuryAPI Programmers Guide and the MercuryAPI SDK, available on the ThingMagic website.

A demo application which supports reading and writing is provided in the MercuryAPI SDK package. The source code for this example is included in the MercuryAPI SDK package under `/cs/samples/exe/Universal-Reader-Assistant.exe`.

See the Readme.txt in `/cs/samples/Universal-Reader-Assistant/Universal-Reader-Assistant` for usage details.

See the *MercuryAPI Programming Guide* for details on using the MercuryAPI.

Note

In some cases the configuration of the Vega differs from that specified for the standalone Mercury5e module. These cases are noted in this document.

In-vehicle Reader Notes

The contents of the *Vega Setup Guide* apply to both the **Vega RS** (Ruggedized System) and the **Vega IVR** (In-Vehicle Reader). The **IVR** variant has the following exceptions:

- ◆ The components included with the product are different, see [Included Components](#).
- ◆ The [ReaderEnable](#) jumper terminator is not included so the ReaderEnable/DTR signal (see [Serial Connector Pin Out](#)) must be managed or the reader will stay off and draw no power.

Included Components

With the Vega RS, you will receive the following components:

- ◆ The ThingMagic Vega reader
- ◆ One, Two or Three antennas and Cables, depending on your configuration
- ◆ Documentation and software development kit packages can be found at <http://rfid.thingmagic.com/devkit>
- ◆ One Jumper Terminator for the [ReaderEnable](#) on the GPIO Connector. (*Not included with the IVR*)

Note: If the ReaderEnable jumper is not connected another method must be used to “turn on” the reader as described in [ReaderEnable](#).

Additional required equipment:

- ◆ Straight-thru DB9 serial cable.
- ◆ USB to Serial adapter (if the connected PC doesn't have an RS232 COM port)
- ◆ One DC power supply with power cord (*Optional*)

Note: This product is intended to be supplied by a Listed power supply marked 'LPS' or 'NEC Class 2' and rated 8-16V, minimum 1A.



W A R N I N G !



The Vega antenna ports may be susceptible to damage from Electrostatic Discharge (ESD). Equipment failure can result if the antenna or communication ports are subjected to ESD. Standard ESD precautions should be taken during installation and operation to avoid static discharge when handling or making connections to the Vega reader antenna or communication ports. Environmental analysis should also be performed to ensure static is not building up on and around the antennas, possibly causing discharges during operation. See the M5e-Family Developer's Guide | Appendix E or contact support@thingmagic.com for more details on ESD.

Setting up Vega

When setting up Vega, use the following procedures:

1. Connecting the Antenna(s)
2. Powering up the Vega
3. Connecting the Serial Cable

Connecting the Antenna(s)

ThingMagic supplies a variety of monostatic antenna types for use with Vega. Vega supports up to three antennas. Use the following procedure to connect the antenna to the Vega.



W A R N I N G !



To prevent damage to Vega, never apply RF power to an antenna port that does not have an antenna or terminator connected to it.

1. If the antenna does not have an integrated cable, connect one end of the coax cable to the antenna.
2. Connect the other end of the coax cable to Ant 1, Ant 2 or Ant 3 antenna port on the front of the module.

Using Three Antennas

The antenna port configuration uses a combination of two configuration settings (antenna port and GPO #1) for the three antennas:

Table 1: Antenna Configuration Settings

Antenna	Port Setting	GPO #1 Setting
Antenna 1	TX=2, RX=2	n/a
Antenna 2	TX=1, RX=1	High
Antenna 3	TX=1, RX=1	Low (<i>default</i>)

Note

In order to use the Antenna 2 port it is necessary to set the antenna configuration and toggle the GPIO Output #1 to High.

When using the MercuryAPI (v1.9 and later) to develop Vega applications the GPIO mapping for antenna configuration is handled for you. You can simply specify antennas as 1, 2 and 3 and they will map to the labels on the Vega. If using low level serial commands the GPIO configuration needs to be handled “manually” using the settings described in the Using a Multiplexer section of the M5e-Family Developer’s Guide to create the mappings in [Antenna Configuration Settings](#)

Powering up Vega

After connecting the antenna (s) and terminating any unused ports, you can power up Vega.

1. Connect the serial cable from a PC to Vega

Table 2: Serial Connector Pin Out

Pin Number	Description
2	RXD – to host
3	TXD – from host
4	DTR – ReaderEnable1 Input
5	Ground
9	+5V

2. Apply 12VDC power to the power input connector, J1.
3. Insure that the ReaderEnable Jumper Terminator is connected to the GPIO connector

For more on the ReaderEnable signal see [Using GPIO and ReaderEnable](#) below

The reader is now powered up and ready to begin reading tags.

Reading Tags

The following procedure explains how to install and activate the Reader Assistant on your PC.

Start the Universal Reader Assistant

1. Get **Universal-Reader-Assistant** from the ThingMagic website, its part of the MercuryAPI SDK package under /cs/samples/exe/Universal-Reader-Assistant.exe, and install it on the computer that is connected to the USB Reader (<http://rfid.thingmagic.com/devkit>).
2. Set up the computer to Vega as described in [Setting up Vega](#)
3. Start the Universal Reader Assistant by double-clicking the executable file Universal-Reader-Assistant.exe.
4. Select the appropriate COM port for Reader URI.

The Universal Reader Assistant senses the COM ports that are located on your system.

When using an RS232 COM port it is typically statically assigned COM1.

If using a USB to Serial adapter, USB devices are typically assigned higher value COM ports. If many COM ports are listed in the menu and you aren't sure which is for the USB Adapter you can find the assigned value using the Windows Device Manager:

- a. Open the Device Manager (located in *Control Panel | System*)
- b. Select the *Hardware* tab and click *Device Manager*"
- c. Select *View | Devices by Type | Ports (COM & LPT)*

The device appears as *USB Serial Port (COM#)*. The USB adapter COM port value is in parentheses.

5. Follow the Readme.txt in /cs/samples/Universal-Reader-Assistant for steps to read and write tags.

Using GPIO and ReaderEnable

Two general purpose inputs, one general purpose output and the ReaderEnable input are provided through a 6 position Tyco Amp 1445049-6 Connector (Mating Shell: 1445022-6, Mating Contact: 794610-3). GPIO describes the pin out for this connector.

GPIO

The GPIO signals can be accessed using the **Config** tab on Reader Assistant as described in the previous section.

Table 3: GPIO connector pin out

Pin Number/ Wire Color	Direction	Vmin	Vmax	Description
1 - J2 White	Input	-0.5	5.5	GPI 1
2 - J2 Brown	Input	-0.5	5.5	GPI 2
3 - J2 Yellow	Output	0	3.6	GPO 2 <i>Note:</i> This is not an open collector output. It is a 74LVC244A output.
4 - J2 Blue	Input	-0.5	Vin + 0.5	ReaderEnable2
5 - J2 Purple	In/Out	8	16	+12V (same as Vin)
6 - J2 Green	In/Out	0	0	Ground

GPIO Logic Voltage Levels

The following are the voltage levels between Ground (Green) and the input or output pin for logic high and low:

Inputs

- ◆ Low - apply a signal between 0 and 0.8 V
- ◆ High - apply a signal between 2 and 5 V

Outputs

- ◆ Low - outputs a maximum 0.4 V and will sink 12mA
- ◆ High - outputs a minimum of 2.4 V and will source 12mA.

Note: Note that there is no GPO-1 connection. This signal is used for switching between antennas 2 and 3.

Figure 1: Connector Cable

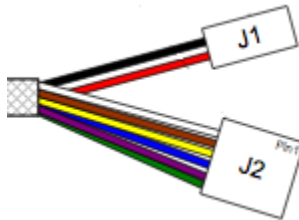

ReaderEnable

There are two connections that can be used to enable the reader. The Serial connector provides access to the ReaderEnable1 signal. The GPIO connector provides access to the ReaderEnable2 signal. At least one of these signals **must** be pulled to greater than +2V for the reader to be active. These signals can be used to remotely turn the power off for power savings. The ReaderEnable Jumper Terminator provided with your reader will connect pins 4 and 5 of the GPIO connector providing +12VDC to the ReaderEnable2 input.

Mechanical

The reader mounting is as shown in [Vega Mechanical \(all dimensions in cm\)](#). The four mounting holes are designed for M4 screws with lock washers and 15mm x 1.5mm flat washers.

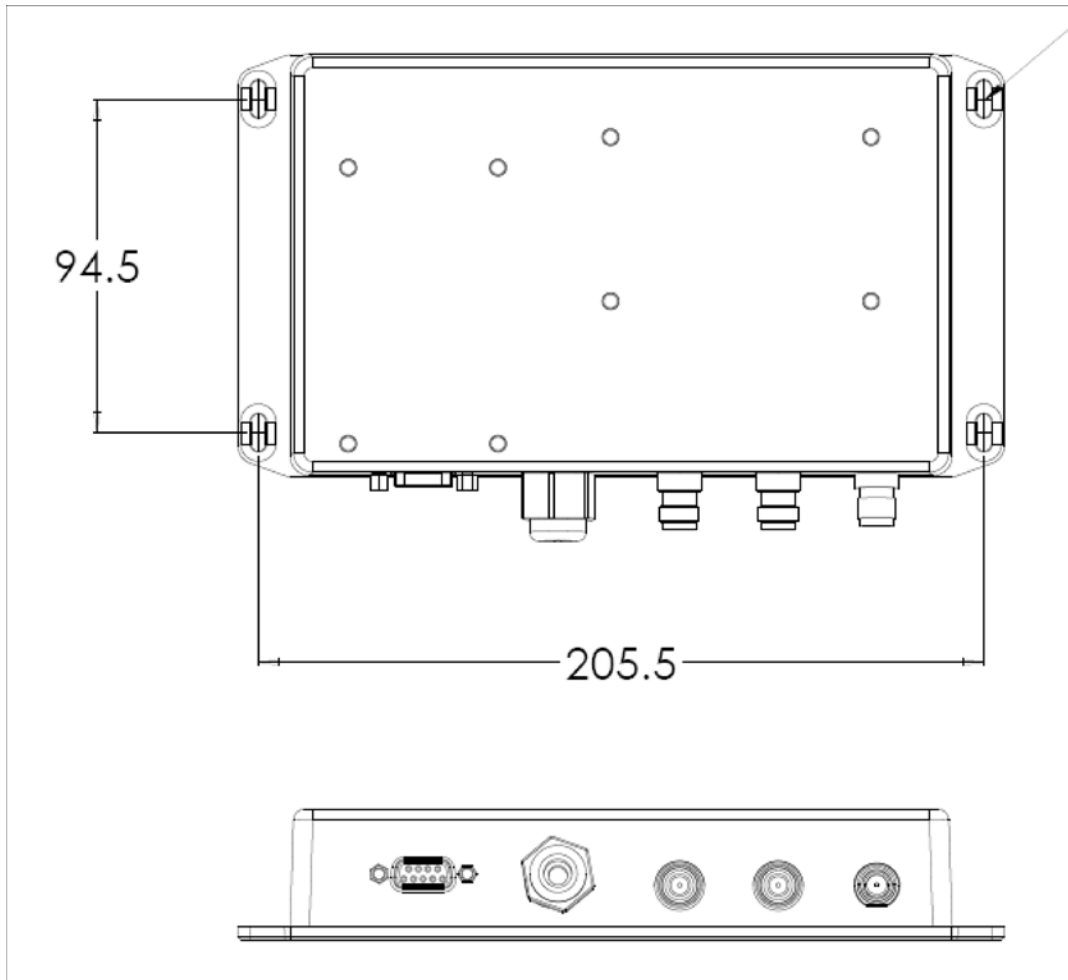

Figure 2: Vega Mechanical (all dimensions in cm)

Mounting the Reader

To mount the reader on a ceiling or wall, follow these steps:

1. Hold the reader in its mounting location and mark the position of the four mounting screws.

2. Drill holes for the screws and install wall or ceiling anchors if required. For ceiling mount, use only anchors specifically designed for ceilings.
3. Hold reader over holes and insert the screws and tighten until almost flush with the wall.
4. Tighten the screws.

Rack Mount Considerations

Elevated Operating Ambient

If installed in a closed or multi-unit rack assembly, the operating ambient temperature of the rack environment may be greater than room ambient. Therefore, consideration should be given to installing the equipment in an environment compatible with the maximum [Operating Temp.](#)

Reduced Air Flow

Installation of the equipment in a rack should be such that the amount of air flow required for safe operation of the equipment is not compromised.

Mechanical Loading

Mounting of the equipment in the rack should be such that a hazardous condition is not achieved due to uneven mechanical loading.

Circuit Overloading

Consideration should be given to the connection of the equipment to the supply circuit and the effect that overloading of the circuits might have on overcurrent protection and supply wiring. Appropriate consideration of equipment nameplate ratings should be used when addressing this concern.

Reliable Earthing

Reliable earthing of rack-mounted equipment should be maintained. Particular attention should be given to supply connections other than direct connections to the branch circuit (e.g. use of power strips).

Vega Specifications

Power

AC/DC Power Required

Reader : 10-16 VDC, 8 W maximum at 12 V when transmitting

Optional AC Power Adapter: 100-240 VDC, 50-60 Hz, 10 W maximum when transmitting

Note

If an AC Power Adapter supply is used it must meet the following criteria:

- Be UL Listed
- Meet the above operating specs
- The output must comply with SELV and LPS characteristics
- Have a maximum operating ambient temperature that meets or exceeds the intended Vega operating temperatures as covered under the UL Listing of the power supply.

Environment

Operating Temp

Reader: -40 C to +75 C

Note

If an external DC power supply with a lower operating ambient temperature, as covered under the UL Listing of the power supply, is used then the operating ambient temperature of the Vega would be reduced accordingly.

Storage Temp

Reader: -40C to +85C

Automotive Environmental Standards

Confirmed to meet in-vehicle standards for:

Powered Thermal Cycle (IEC 68-2-14wNb)
Thermal Shock Resistance A & B (IEC 68-2-14Na)
Powered Vibration Endurance (IEC 68-2-6)
Mechanical Shock (IEC 68-2-32, 68-2-27)
Humidity-Temperature Cycle (
Water/Fluids Ingress (IEC Pub. 529 Sec. 14.2)
Connector/Harness Pull-Push (
Voltage Overstress
Electrostatic Discharge

Electrostatic Discharge

- IEC-61000-4-2 discharge direct to operational antenna port tolerates max 300 Volt Pulse
- MIL-883 3015.7 discharge direct to operational antenna port tolerates max 1200 Volt Pulse

Survival level varies with antenna return loss and antenna characteristics. See the *M5e-Family Developers Guide* for methods to increase ESD tolerances.

Architecture

RFID ASIC

Intel R1000

User-accessible Flash Memory

16 kB

Tag Buffer

200 tags

Performance

Tag Read Rate

Up to 190 tags/second

Tag Read Distance

Over 30 feet (9 m) with 6 dBi antenna (36 dBm EIRP)

Tag / Transponder Protocols

RFID Protocol Support

EPCglobal Gen 2 (ISO 18000-6C) with Anti-Collision, DRM, and advanced anti-jamming

Regional Support

Certification obtained or in progress for the following regions: North and South America, EU, Korea and other Asia-PAC countries.

RF Interface

Antenna Connector

Three reverse-TNC antenna ports supporting monostatic 50 Ohm antennas (for best performance VSWR should be less than 1.5:1 in operating frequency range).

RF Power Output

Separate read and write levels, command-adjustable from 5 dBm to 30 dBm (1 W), +/-1.0 dBm accuracy.

Data/Control Interface

Data/Control

9-pin serial connector, supporting RS232 with asynchronous data rates up to 921.6 kbps. DTR signal turns off reader completely to conserve power.

GPIO Sensors and Controls

2 General Purpose inputs and one output, accessible via Molex Connector

Protocol

Command-response protocol protected by length field and 16-bit CRC.

Physical

Dimensions

8.5 in L x 5.25 in W x 1.5 in H
(21.6 cm x 13.3 cm x 3.8 cm)

Compliance Information

FCC COMPLIANCE

FCC ID: QV5SR5E

This equipment complies with Part 15 of the FCC rules for intentional radiators and Class A digital devices when installed and used in accordance with the instruction manual.

Following these rules provides reasonable protection against harmful interference from equipment operated in a commercial area.

This equipment should not be installed in a residential area as it can radiate radio frequency energy that could interfere with radio communications, a situation the user would have to fix at their own expense.

This device has been designed to operate with the antennas provided with it (MTI MT-262024) and having a maximum gain of 7dBic. Antennas not listed here or having a gain greater than 7dBic are strictly prohibited for use with this device. The required antenna impedance is 50 ohms.

To reduce radio interference to other users, the antenna type and its gain is chosen such that the equivalent isotropically radiated power (EIRP) is not more than permitted for successful communication.

EQUIPMENT MODIFICATION CAUTION

Equipment changes or modifications not expressly approved by ThingMagic, Inc., the party responsible for FCC compliance, could void the user's authority to operate the equipment and could create a hazardous condition.

IMPORTANT USER INFORMATION

In order to comply with FCC and IC requirements for RF exposure safety, a separation distance of at least 20 cm (7.9 in) needs to be maintained between the radiating elements of the antenna and the bodies of nearby persons.

